

Sales Drawing

Electrical Testing

As Xiangwei standard test plans and Mil-Std-202 Test Method.

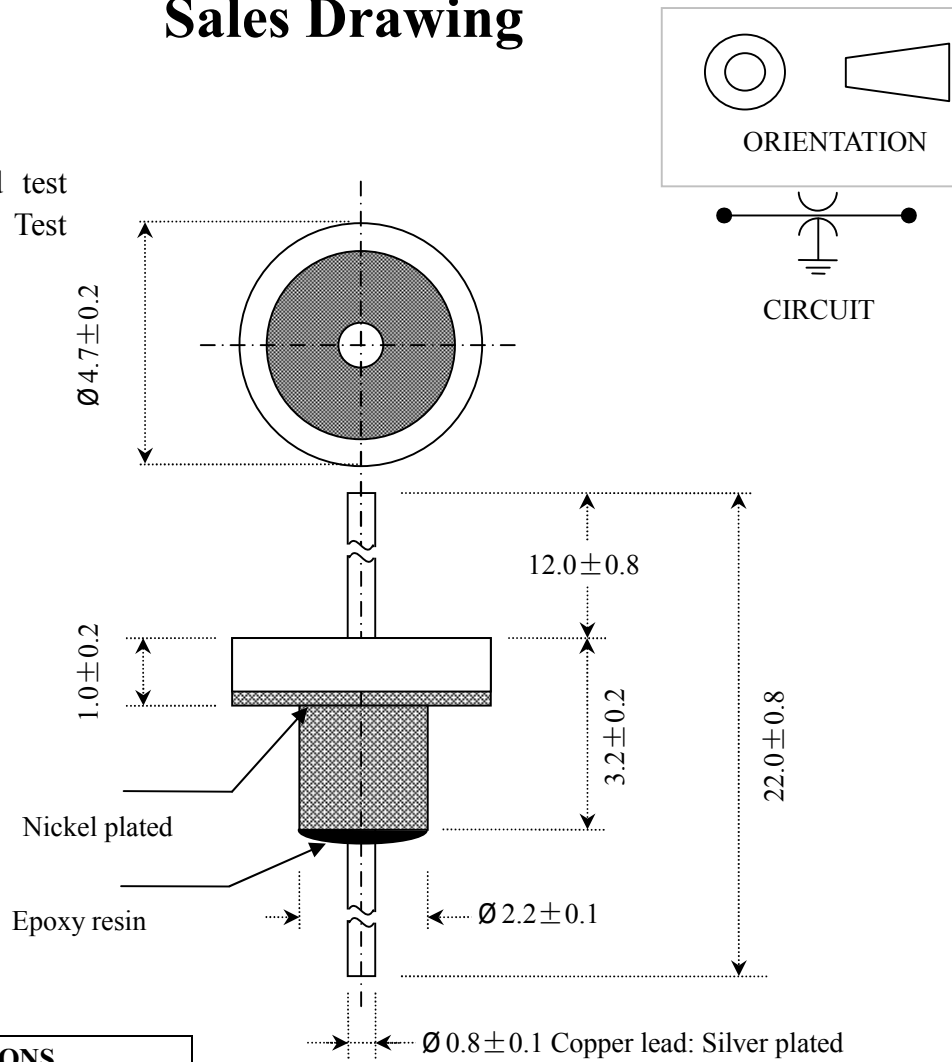

SPECIFICATIONS

Capacitance	1000pF
Dissipation Factor	< 3.5%
Capacitance Tolerance	-20%+80%
Temp Characteristics	X7R
Rating Voltage	100VDC
DWV	300VDC
Current	7A
I.R.100vdc	3000M Ω
Operating Range	-55 $^{\circ}$ C+125 $^{\circ}$ C

Notes:

1. Do not use a hard object beat capacitor body.
2. Storage: Usual temperature by sealed.
3. Soldering: Using constant electric iron soldering, and don't use furnace welding and dip soldering methods.
4. ROHS Part (Lead free).

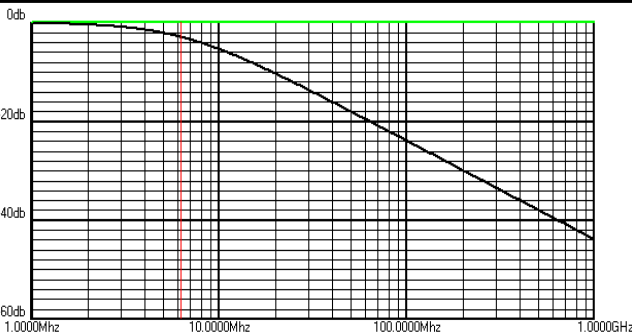

-Tolerances-

Soldering Temp: $\leq 300^{\circ}$ C

Soldering Time: 3sec

LCA[®]

LCA

Micronics

Unit: (mm)

H4722-001